

Soil & Vent Design & Installation

Jointing & Support

Push-fit (Ring Seal) Jointing

- 1) Where plain end pipe is being used, ensure that the pipe is cut square to its axis and that all burrs are removed.
- 2) Chamfer the end of the pipe to prevent the ring seal being damaged or displaced when the pipe is inserted into the socket. Fittings with spigot ends are moulded with chamfer during manufacture.
- 3) Lubricate the spigot or ring seal with silicone grease or aerosol lubricant.
- 4) Insert the pipe or fitting into the socket and then withdraw it by approx. 10mm to allow for expansion of the pipework.

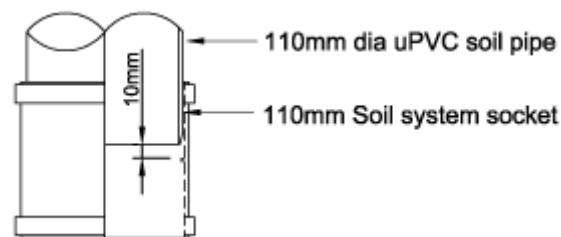

Solvent Weld Jointing

- 1) Ensure that the pipe is cut square and that all burrs are removed.
- 2) Ensure that both surfaces to be jointed are dry and free from dust or other debris.
- 3) Use Polypipe cleaning fluid to remove any surface grease from the spigot and socket to be jointed.
- 4) Apply a coat of Polypipe solvent cement to both surfaces to be jointed using the brush applicator provided in the lid of the tin. The cement should be applied along the length of the spigot and not around its diameter.
- 5) The spigot should be inserted into the socket immediately, with a slight twisting action.
- 6) Any surplus solvent cement should be removed with a clean cloth.
- 7) The joint will be strong enough to handle approx. 5 minutes and can be tested after 12 hours.

The following table indicates the approximate number of joints that can be made for each pipe diameter with solvent cement, cleaning fluid and silicone grease.

	Pipe Diameters						
	19mm	32mm	40mm	50mm	82mm	110mm	160mm
Solvent Cement 125ml Code SC125	85	45	35	20	9	5	3
Solvent Cement 250ml Code SC250	175	90	70	40	18	10	6
Solvent Cement 500ml Code SC500	350	180	140	80	35	20	12
Cleaning Fluid 250ml Code CF250	250	140	120	75	30	20	15
Silicone Grease 100gm Code SG100		100	85	45	35	20	10

Support

The following table shows recommended maximum pipe support centres for horizontal and vertical pipework:

	Pipe Diameters						
	19mm	32mm	40mm	50mm	82mm	110mm	160mm
Horizontal	0.6m	0.5m	0.5m	0.5m	0.9m	0.9m	0.9m
Vertical	0.6m	1.2m	1.2m	1.2m	1.8m	1.8m	1.8m

Branch Connection Details

The following information shows the requirements of the Building Regulations with regard to lengths of unventilated branch discharge pipes and corresponding gradients.

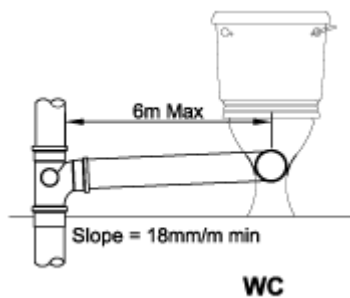

1. Requirement for single WC
2. A maximum of 8 WC's may be connected to an unventilated soil branch. The length is limited to 15m max. in this case
3. Pipe diameter = 110mm
4. It is only permitted to use 82mm dia. pipework when the outlet of the WC pan itself is less than 80mm diameter

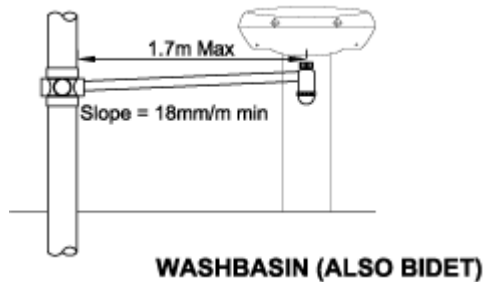

1. Where maximum length is exceeded, an antisiphon trap or anti-siphon unit should be used
2. Pipe diameter = 32mm
3. If 40mm dia. pipe is used, max length is 3m



1. Pipe diameter = 40mm
2. If 50mm dia. pipe is used, max length is 4m

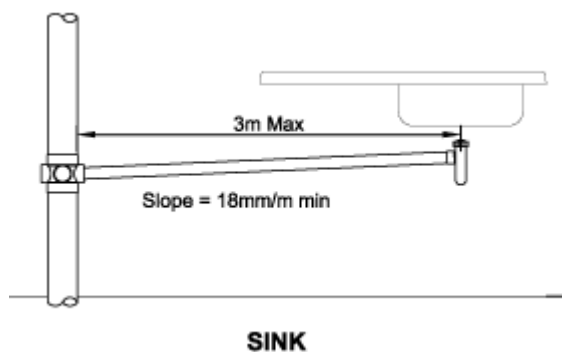

1. Pipe diameter = 40mm
2. If 50mm dia. pipe is used, max length is 4m

Prevention of Crossflow

Where a branch enters a stack, it creates a zone on the opposite wall of the stack where no connections may be made.

Where the branch pipe diameter is less than 65mm, the no connection zone is 110mm deep on a 110mm diameter stack and 250mm deep on a 160mm diameter stack, measured from the centre line of the incoming branch pipe.

Where the branch pipe exceeds 65mm, the no connection zone is 200mm irrespective of stack diameter.

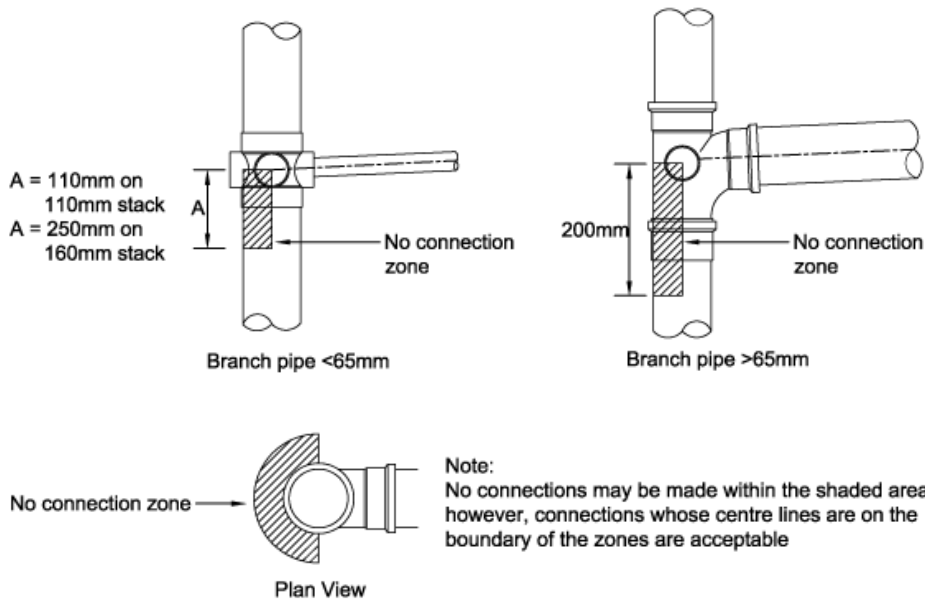

Soil Manifold

The MAN5 Soil Manifold is available in order to overcome the problem of crossflow whilst maintaining the facility to connect waste pipes to the soil stack above floor level.

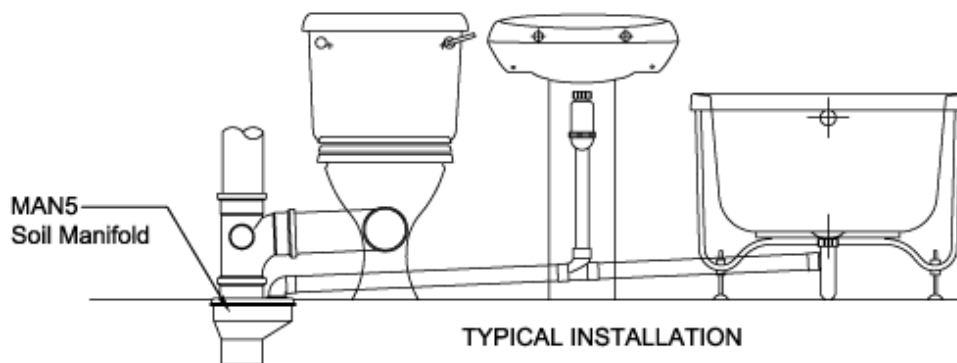

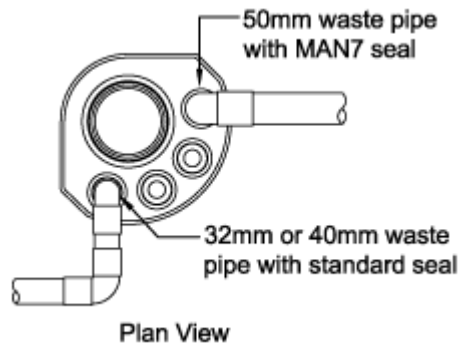

The manifold is supplied with four blanked-off push-fit connection points, the plugs from which can be removed to connect 32mm or 40mm waste pipes in any combination.

Where 50mm waste pipes are to be connected, the relevant hole is enlarged to the template moulded into the fitting and the existing seal is replaced with the MAN7 50mm seal.

Boss Connections

All boss shoulders provided on bossed pipes, branches, strap bosses etc. are a common size and will accept 32mm, 40mm and 50mm waste pipes using a comprehensive range of boss adaptors. Where a boss shoulder is moulded solid, it should be drilled through with a 60mm diameter hole saw.

Note: Boss Adaptors with universal push-fit or compression joints will accept polypropylene, ABS, muPVC or copper waste pipes.

STRAIGHT/ANGLED BOSS ADAPTOR

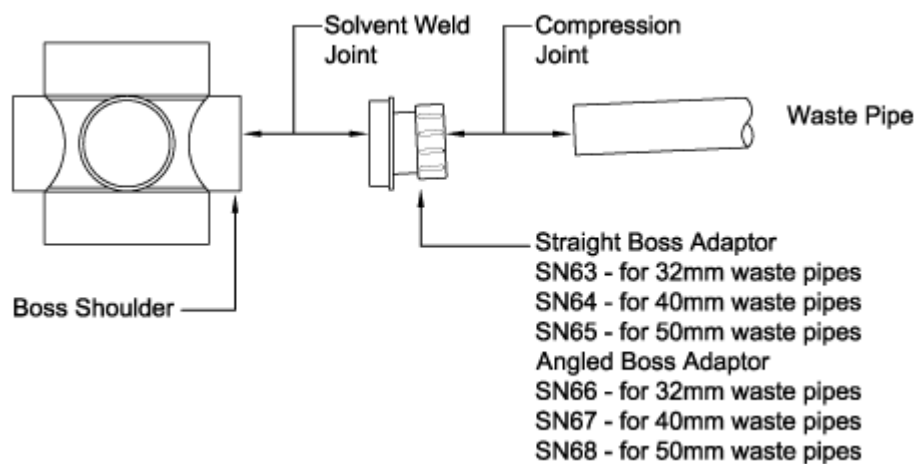

BOSS ADAPTOR (RUBBER)

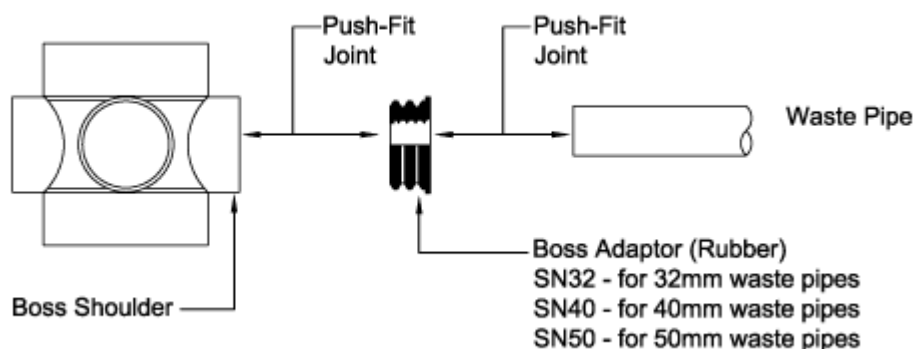

BOSS ADAPTOR (SOLVENT)

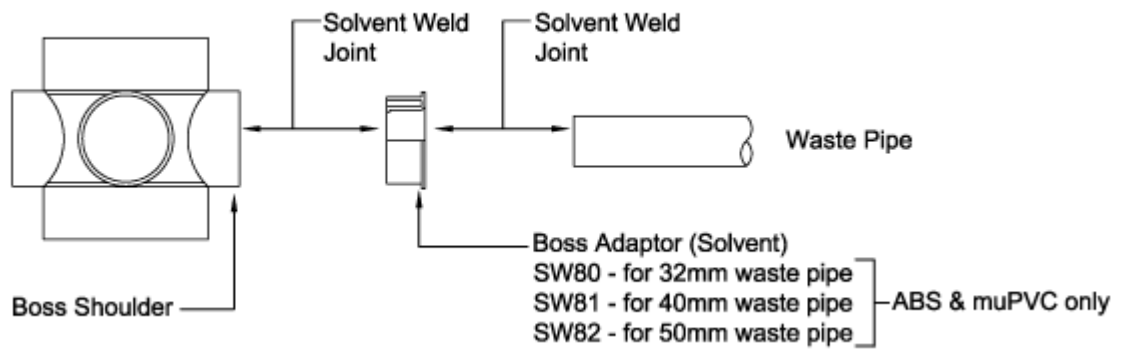

Access

Where the discharge stack has a long drain connection to an inspection chamber, access for rodding and testing should be provided at or near the base of the stack. When ground floor appliances are connected to the soil stack, the access point should be sited above the spillover level of the appliances.

For multi-storey domestic buildings, access into the stack should be provided at 3 storey intervals and for multi-storey commercial buildings access should be provided on each floor.

